



ZCC Cutting Tools
Europe GmbH



ZCC Cutting Tools Europe GmbH

Product Innovations 09/2024

[QF chip breaker – SMP09 slot mill cutting system –
zClamp Hydro hydraulic expansion chucks]

– EN –

The Company

Zhuzhou Cemented Carbide Cutting Tools Co., Ltd. (ZCC-CT), based in Zhuzhou, China, is the largest Chinese manufacturer of carbide tools. It is also a key company of China Tungsten High-Tech Material Co. Ltd. part of the China Minmetals Corporation.

Since its founding in 1953, ZCC Cutting Tools Co., Ltd. has grown to become one of the world's leading carbide manufacturers with more than 2,000 employees by using the latest technologies and employing highly skilled personnel. The company continuously modernises production technologies and expands its production capacities to enable the company's ongoing growth. As part of Minmetals Corporation, ZCC-CT is able to cover the entire value chain of modern carbide tool production itself, from raw material extraction through to the coated end product and all associated intermediate steps.

By drawing on the latest in European production technology, the company offers products that consistently meet the highest quality standards. Our extensive product range includes carbide/solid carbide, cermet, CBN, PCD and ceramic inserts, carbide tools, tool holders, milling bodies and the accompanying tool systems. All products are consistently produced to accepted international standards, including ISO, DIN, ANSI, JIS and BSI. In addition, ZCC-CT offers customised solutions and special carbide products built to individual specifications.

ZCC-CT invests heavily in research and development. The associated investments go beyond that of most competitors. ZCC Cutting Tools' excellently trained engineers, scientists and a competent, international team, research the necessary fundamentals. These form the basis for the ongoing development of new products and the improvement of existing ones.

The company continuously introduces improvements in quality to meet the customers' ever-increasing demands for new and innovative products and to maximise the benefit of each individual

customer. Both production and administration in China are subject to the ISO 9001:2008 standard, while environmental management is subject to the requirements set out in ISO 14001:2004.

The foundation of the European headquarters of ZCC-CT, ZCC Cutting Tools Europe GmbH and the European central warehouse, both located in Düsseldorf (Germany), dates back to 2003. Today, all European countries as well as the adjacent markets are served from there.

The quality management system of ZCC Cutting Tools Europe GmbH is certified in the area of 'distribution and logistics of metal-working tools' in accordance with ISO 9001:2008.

The Test and Demonstration Centre is available for optimizing customer processes according to individual requirements.

External sales staff and distribution partners in Europe work hand in hand to support customers across the region. Our friendly ZCC-CT application engineers are also available to support you with their expertise and experience by phone, e-mail or in person at your production facility.

The entire field and office sales force is available to answer enquiries from clients across Europe in their native language. Together with employees from the logistics team and with the help of a sophisticated service system, they ensure that all orders are delivered as quickly as possible to you. Branch offices in France and Great Britain add to additional regional proximity to customers.

ZCC Cutting Tools Europe GmbH and all of our employees are there for you and have your back as a competent partner for all matters concerning machining production. This is how we define 'your partner – your value'.

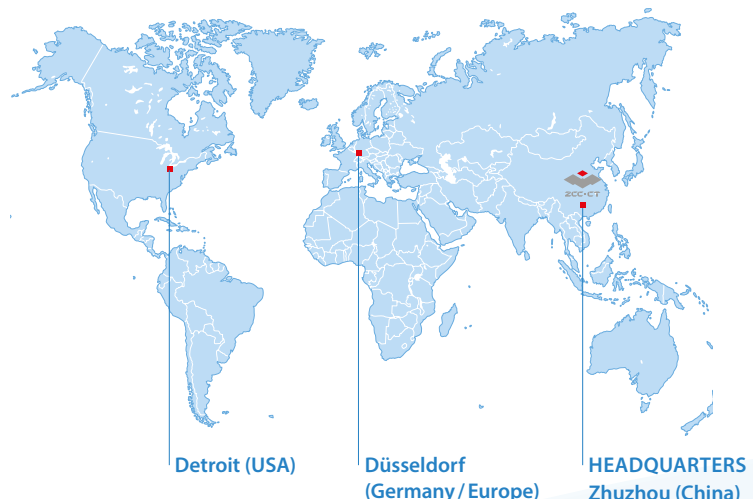

This brochure will be presenting the following new products:

Product Innovations 09 / 2024

GENERAL TURNING

Page



QF chip breaker – Maximum chip control in finishing operations

A10

INDEXABLE MILLING

Page



SMP09 slot mill cutting system – Highly versatile tangential milling system

A20

TOOL HOLDERS

Page



zClamp Hydro hydraulic expansion chucks – Secure tool clamping for maximum process reliability

A32

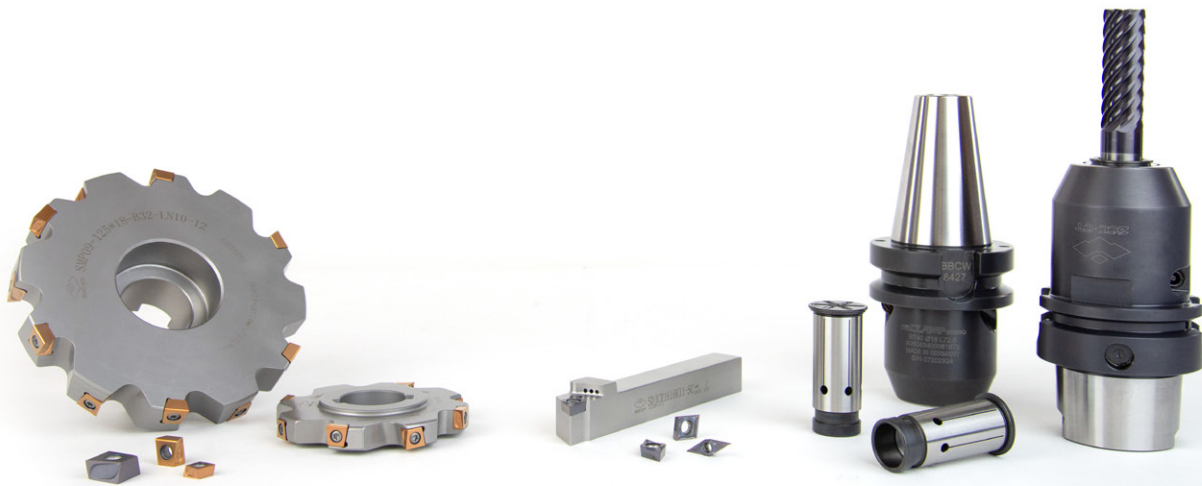

A glimpse inside: Highlights from previous Product Innovations brochures

Product Innovations 09 / 2023

GENERAL TURNING

XLR chip breaker – Roughing made easy

ONMX high feed turning system – New Octa insert and tool holder series for efficient turning applications

PNMX high feed turning system – New Penta insert and tool holder series for efficient turning applications

THREADING

zType threading tool holders with internal cooling – New series for high-quality results in threading operations

SOLID CARBIDE DRILLING

FD flat drills – 180° solid carbide drills for any application



[Go to PDF online](#)

Product Innovations 03 / 2023

GENERAL TURNING

YBG205H grade – The perfect choice for high-temperature turning applications

PARTING & GROOVING

MU chip breaker – Universal tool that delivers optimum chip control

INDEXABLE MILLING

FME17 face milling system – Highly efficient universal tool for machining end faces and contours

EMP05 plunge milling system – Universal tool for any machining application

FMR06 round insert milling cutter – Maximum cutting performance

CSX1000 grade – High-performance grade for superalloys

APL chip breaker – Universal geometry



[Go to PDF online](#)

Product Innovations 09 / 2022

GENERAL TURNING

XMH chip breaker – Semi-finishing made easy

THREADING

zType threading inserts – New series for high-quality results in threading operations

INDEXABLE MILLING

FMA12 face milling system – Now available in new ONHU09T5 insert size

EMP14 aluminium milling system – Precisely 90° for shoulder milling operations

FMR11 round insert milling cutter – Maximum cutting performance

SOLID CARBIDE MILLING

VPM series – Now also available as a torus milling cutter/with Weldon clamping surface



[Go to PDF online](#)

GENERAL TURNING

miniTURN – New YPG202 grade for enhanced performance

INDEXABLE MILLING

YBG205H grade – Optimal for high-temperature applications

FMP06 – High-performance hard machining with 88° approach angle

FMA17 – Versatile milling system for efficient facing operations

FMP17 – Efficient universal tool for machining end faces and contours

FMR04 – Extension: Now with new inserts and chip breakers

SOLID CARBIDE MILLING

TM series – Expanded line with compact torus milling cutters from Ø1.0 mm

VPM series – High-speed full-slot milling

SOLID CARBIDE DRILLING

UD series – Extension: Now available in diameters from 1.0 mm with internal cooling



[Go to PDF online](#)

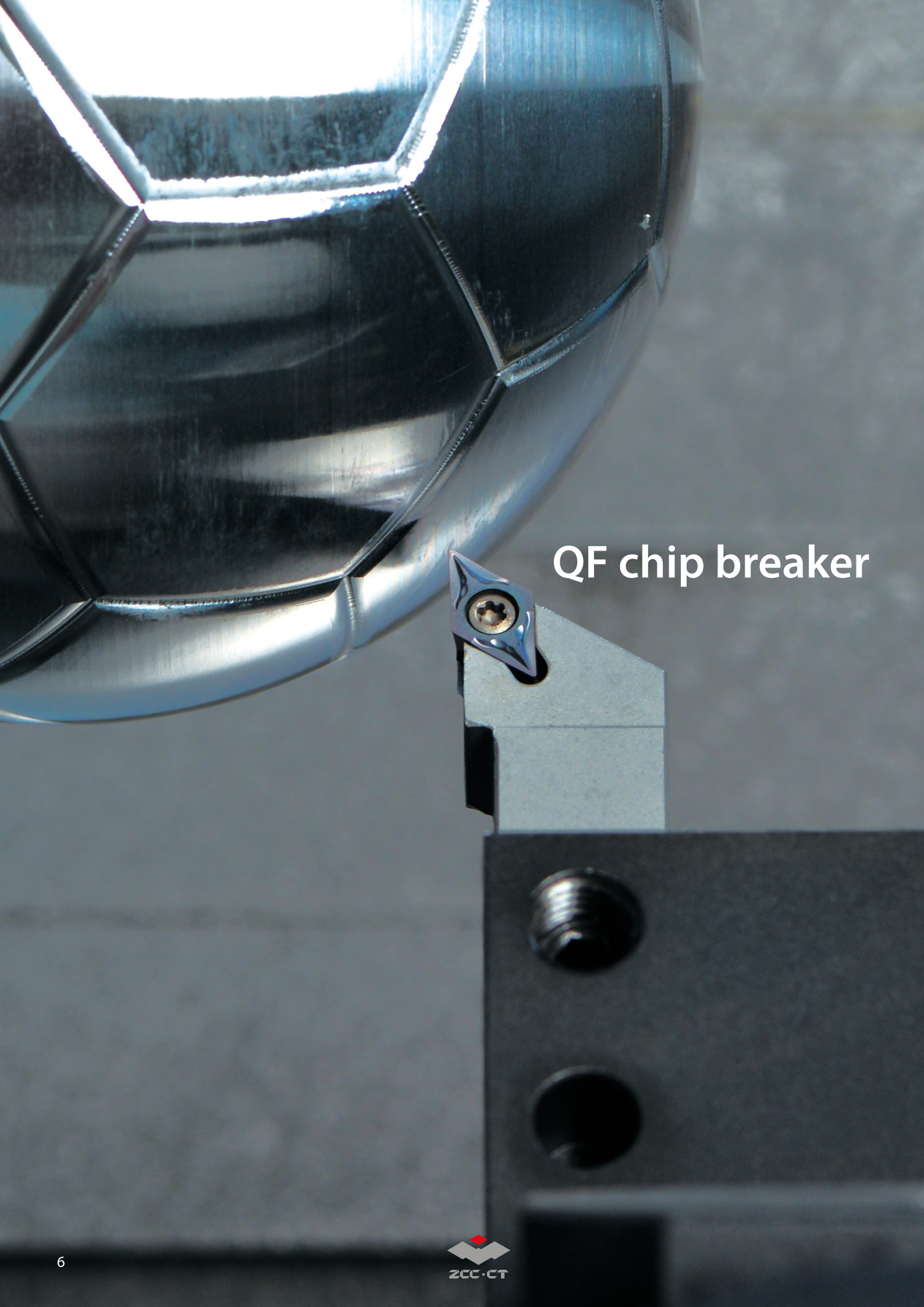

QF chip breaker

General turning

ISO code – general turning inserts

A8–A9

QF chip breaker

A10–A13

A

A

Turning

B

Milling

C

Drilling

D

Technical
Information

















E

Index









ISO standard

T N M G 22 04 08 (N) – DM

1 2 3 4 5 6 7 8 9

Insert shape		
A 	B 	C 
D 	E 	H 
K 	L 	M 
O 	P 	R 
S 	T 	V 
W 	Z Special	















1

Clearance angle	
A 	B 
C 	D 
E 	F 
G 	N 
P 	O Special









2

Tolerance class			
Code	I.C [mm]	m [mm]	S [mm]
A	±0,025	±0,005	±0,025
C	±0,025	±0,013	±0,025
E	±0,025	±0,025	±0,025
F	±0,013	±0,005	±0,025
G	±0,025	±0,025	±0,130
H	±0,013	±0,013	±0,025
J	±0,05–0,15	±0,005	±0,025
K	±0,05–0,15	±0,013	±0,025
L	±0,05–0,15	±0,025	±0,025
M	±0,05–0,15	±0,08–0,20	±0,130
N	±0,05–0,15	±0,08–0,20	±0,025
U	±0,08–0,25	±0,13–0,38	±0,130

3

Fastening features (metric)	
Insert shape	
A 	B 
C 	F 
G 	H 
J 	M 
N 	Q 
R 	T 
U 	W 
X Special	

4

Cutting edge length l [mm]								
I.C [mm]	Insert shape							
								
3,97	06							
5,0	05							
5,56	09							
6,0	06							
6,35	06	07	11			11		
8,0	08							
9,525	09	11	09	09	16	16	06	16
10,0	10							
12,0	12							
12,7	12	15	12	12	22	22	08	
15,875	16		15	15	27			
16,0	16							
19,05	19		19	19	33			
20,0	20							
25,0	25	25	25					
25,4	25							
31,75	31							
32	32							

5

Insert thickness S [mm]			
Code	S	Code	S
00	0,79	T5	5,95
T0	0,99	06	6,35
01	1,59	T6	6,75
T1	1,98	07	7,94
02	2,38	09	9,52
T2	2,58	T9	9,72
03	3,18	11	11,11
T3	3,97	12	12,70
04	4,76		
T4	4,96		
05	5,56		

6

Nose radius r [mm]	
Code	r
00	–
02	0,2
04	0,4
08	0,8
12	1,2
16	1,6
20	2,0
24	2,4
32	3,2
X	Special
MO	Round inserts

7

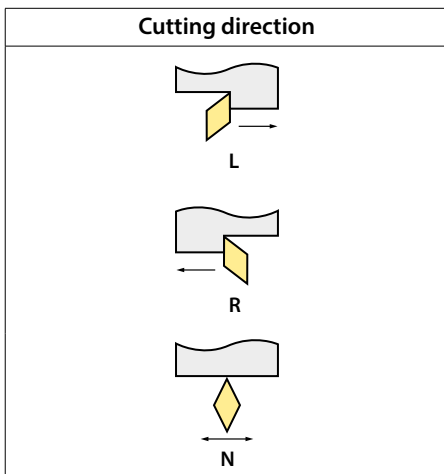

8

Chip breaker overview
(on page A16 in the Main Catalogue)

9

ANSI standard



Inner circle		
Code	[mm]	Pouce
2	6.35	0.250
3	9.525	0.375
4	12.7	0.500
5	15.875	0.625
6	19.05	0.750
8	25.4	1.000

5

Insert thickness		
Code	[mm]	Pouce
2	3.18	0.125
3	4.76	0.187
4	6.35	0.250
5	7.94	0.313
6	9.52	0.375

6

Nose radius		
Code	[mm]	Pouce
0	0.2	0.008
1	0.4	0.016
2	0.8	0.031
3	1.2	0.047
4	1.6	0.063
5	2.0	0.079
6	2.4	0.094

7

QF chip breaker

Maximum chip control in finishing operations

YOUR BENEFITS

- **Maximum chip control** and **top-notch surface quality** across a wide range of applications
- Optimally prepared cutting edges for **minimal vibration** when machining thin-walled components
- Peripherally ground cutting edges ensure a **high level of precision**

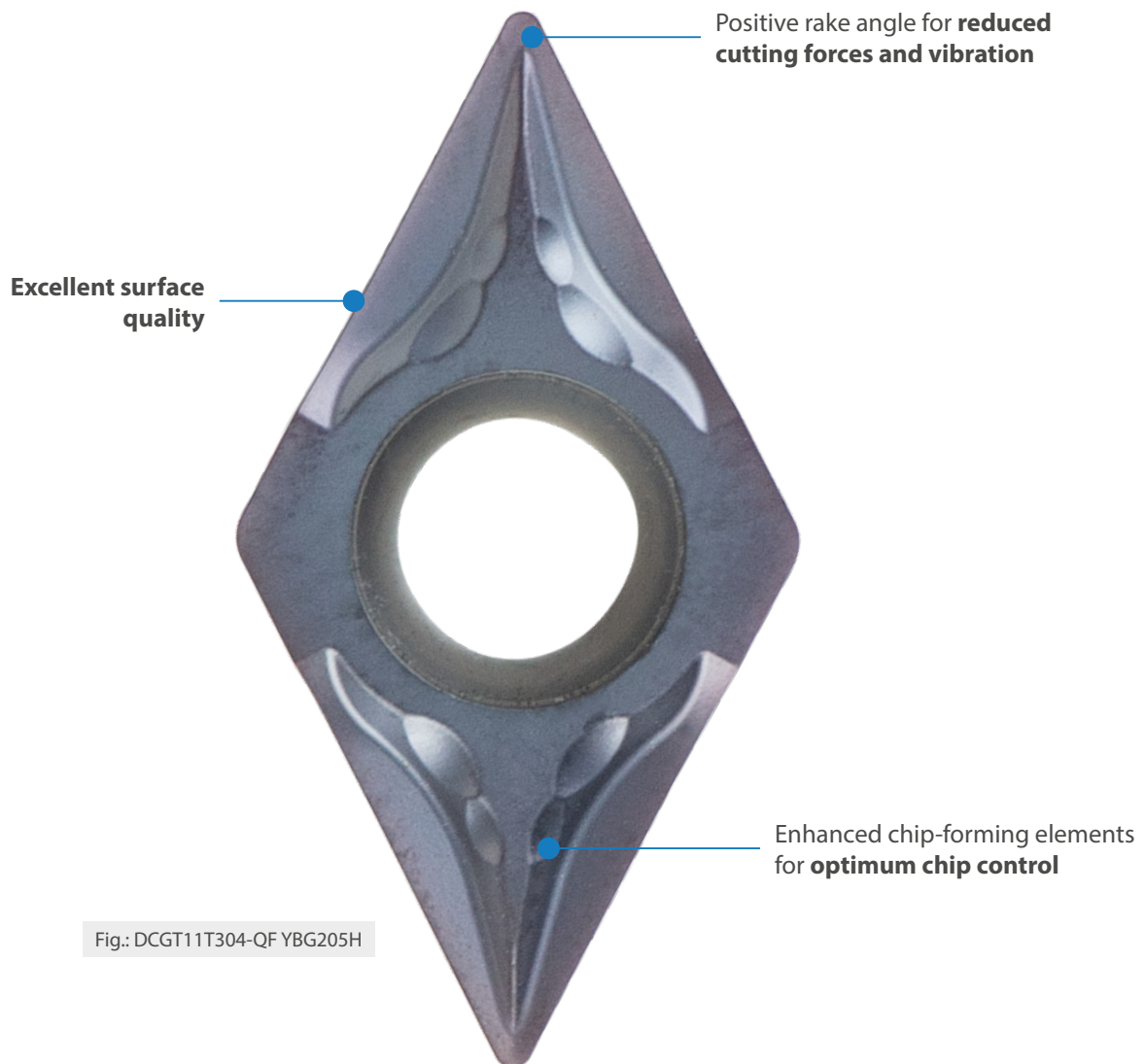

- Ideal machining conditions
- Normal machining conditions
- Unfavourable machining conditions

CCGT	L	I.C	S	d
06 02	6,4	6,35	2,38	2,8
09 T3	9,7	9,525	3,97	4,4

Turning inserts

CC** positive insert				HC ¹ (CVD)								HC ¹ (PVD)		HT	HC ²	HW	
ISO	r	a _p	f	P	M	K	N	S	H								
				YBC103	YBC103	YBC103	YBC103	YBC103	YBC103	YBC103	YBC103	YBC103	YBC103	YBC103	YBC103	YBC103	YBC103
YB6315	YB6315	YB6315	YB6315	YB6315	YB6315	YB6315	YB6315	YB6315	YB6315	YB6315	YB6315	YB6315	YB6315	YB6315	YB6315	YB6315	
YBC152	YBC152	YBC152	YBC152	YBC152	YBC152	YBC152	YBC152	YBC152	YBC152	YBC152	YBC152	YBC152	YBC152	YBC152	YBC152	YBC152	
YBC203	YBC203	YBC203	YBC203	YBC203	YBC203	YBC203	YBC203	YBC203	YBC203	YBC203	YBC203	YBC203	YBC203	YBC203	YBC203	YBC203	
YBC252	YBC252	YBC252	YBC252	YBC252	YBC252	YBC252	YBC252	YBC252	YBC252	YBC252	YBC252	YBC252	YBC252	YBC252	YBC252	YBC252	
YBC352	YBC352	YBC352	YBC352	YBC352	YBC352	YBC352	YBC352	YBC352	YBC352	YBC352	YBC352	YBC352	YBC352	YBC352	YBC352	YBC352	
YBM153	YBM153	YBM153	YBM153	YBM153	YBM153	YBM153	YBM153	YBM153	YBM153	YBM153	YBM153	YBM153	YBM153	YBM153	YBM153	YBM153	
YBM253	YBM253	YBM253	YBM253	YBM253	YBM253	YBM253	YBM253	YBM253	YBM253	YBM253	YBM253	YBM253	YBM253	YBM253	YBM253	YBM253	
YBD102	YBD102	YBD102	YBD102	YBD102	YBD102	YBD102	YBD102	YBD102	YBD102	YBD102	YBD102	YBD102	YBD102	YBD102	YBD102	YBD102	
YB7315	YB7315	YB7315	YB7315	YB7315	YB7315	YB7315	YB7315	YB7315	YB7315	YB7315	YB7315	YB7315	YB7315	YB7315	YB7315	YB7315	
YBD152	YBD152	YBD152	YBD152	YBD152	YBD152	YBD152	YBD152	YBD152	YBD152	YBD152	YBD152	YBD152	YBD152	YBD152	YBD152	YBD152	
YBD152C	YBD152C	YBD152C	YBD152C	YBD152C	YBD152C	YBD152C	YBD152C	YBD152C	YBD152C	YBD152C	YBD152C	YBD152C	YBD152C	YBD152C	YBD152C	YBD152C	
YBG101	YBG101	YBG101	YBG101	YBG101	YBG101	YBG101	YBG101	YBG101	YBG101	YBG101	YBG101	YBG101	YBG101	YBG101	YBG101	YBG101	
YBG102	YBG102	YBG102	YBG102	YBG102	YBG102	YBG102	YBG102	YBG102	YBG102	YBG102	YBG102	YBG102	YBG102	YBG102	YBG102	YBG102	
YBG105	YBG105	YBG105	YBG105	YBG105	YBG105	YBG105	YBG105	YBG105	YBG105	YBG105	YBG105	YBG105	YBG105	YBG105	YBG105	YBG105	
YBG205H	YBG205H	YBG205H	YBG205H	YBG205H	YBG205H	YBG205H	YBG205H	YBG205H	YBG205H	YBG205H	YBG205H	YBG205H	YBG205H	YBG205H	YBG205H	YBG205H	
YB9320	YB9320	YB9320	YB9320	YB9320	YB9320	YB9320	YB9320	YB9320	YB9320	YB9320	YB9320	YB9320	YB9320	YB9320	YB9320	YB9320	
YPD201	YPD201	YPD201	YPD201	YPD201	YPD201	YPD201	YPD201	YPD201	YPD201	YPD201	YPD201	YPD201	YPD201	YPD201	YPD201	YPD201	
YBS103	YBS103	YBS103	YBS103	YBS103	YBS103	YBS103	YBS103	YBS103	YBS103	YBS103	YBS103	YBS103	YBS103	YBS103	YBS103	YBS103	
YNG151	YNG151	YNG151	YNG151	YNG151	YNG151	YNG151	YNG151	YNG151	YNG151	YNG151	YNG151	YNG151	YNG151	YNG151	YNG151	YNG151	
YNT251	YNT251	YNT251	YNT251	YNT251	YNT251	YNT251	YNT251	YNT251	YNT251	YNT251	YNT251	YNT251	YNT251	YNT251	YNT251	YNT251	
YNG151C	YNG151C	YNG151C	YNG151C	YNG151C	YNG151C	YNG151C	YNG151C	YNG151C	YNG151C	YNG151C	YNG151C	YNG151C	YNG151C	YNG151C	YNG151C	YNG151C	
YD101	YD101	YD101	YD101	YD101	YD101	YD101	YD101	YD101	YD101	YD101	YD101	YD101	YD101	YD101	YD101	YD101	
YD201	YD201	YD201	YD201	YD201	YD201	YD201	YD201	YD201	YD201	YD201	YD201	YD201	YD201	YD201	YD201	YD201	

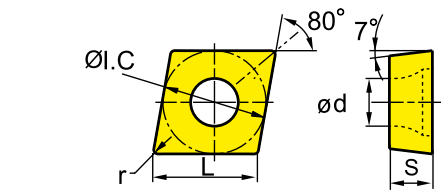

● Ex stock ○ On demand

HC¹ Coated carbide
 HT Uncoated cermet
 HC² Coated cermet
 HW Uncoated carbide

Tool holder						
SCACR/L	SCLCR/L	SCACR/L-SC	SCLCR/L-SC	S***-SCLCR/L	S***-SCFCR/L	S***-SCLCR
Kr: 90°	Kr: 95°	Kr: 90°	Kr: 95°	Kr: 95°	Kr: 90°	Kr: 95°
A269	A270	A306	A307	A334	A352	A353
E***-SCLCR/L						
Kr: 95°						
A355						

A Turning
B Milling
C Drilling
D Technical Information
E Index

General turning Positive inserts

A

Turning

- Ideal machining conditions
- ⊗ Normal machining conditions
- ⊗ Unfavourable machining conditions

DC**	L	I.C	S	d
07 02	7,8	6,35	2,38	2,8
11 T3	11,6	9,525	3,97	4,4

Turning inserts

DC** positive insert		HC ¹ (CVD)					HC ¹ (PVD)		HT	HC ²	HW	
	P	●	●	●	⊗	⊗		●	⊗	●		
	M				●	⊗		●	⊗	●		
	K				●	⊗	⊗					
	N							●	●		●	⊗
	S							●	●	●	⊗	
	H											

B

Milling

	ISO	r	a _p	f	YBC103	YB6315	YBC152	YBC203	YBC252	YBC352	YBM153	YBM253	YBD102	YB7315	YBD152	YBD152C	YBG101	YBG102	YBG105	YBG205H	YB9320	YPD201	YBS103	YNG151	YNT251	YNG151C	YD101	YD201	
					QF	DCGT070201-QF	0,1	0,05-0,2	0,03-0,1															●					
	DCGT070202-QF	0,2	0,1-0,5	0,05-0,2															●										
	DCGT070204-QF	0,4	0,4-1,0	0,1-0,3															●										
Finishing	DCGT11T301-QF	0,1	0,05-0,2	0,03-0,1															●										
	DCGT11T302-QF	0,2	0,1-0,5	0,05-0,2															●										
	DCGT11T302-QF	0,2	0,1-0,5	0,05-0,2															●										
	DCGT11T302-QF	0,2	0,1-0,5	0,05-0,2															●			●							
	DCGT11T304-QF	0,4	0,4-1,0	0,1-0,3															●										
	DCGT11T304-QF	0,4	0,4-1,0	0,1-0,3															●							●			
	DCGT11T304-QF	0,4	0,4-1,0	0,1-0,3															●								●		
	DCGT11T308-QF	0,8	0,5-2,0	0,15-0,35															●										
	DCGT11T308-QF	0,8	0,5-2,0	0,15-0,35															●								●		

● Ex stock ○ On demand

HC¹ Coated carbide
 HT Uncoated cermet
 HC² Coated cermet
 HW Uncoated carbide

C

Drilling

D

Technical Information

Tool holder						
SDACR/L	SDJCR/L	SDNCN	SDACR/L-SC	SDHCR/L-SC	SDJCR/L-SC	SDNCN-SC
Kr: 90°	Kr: 93°	Kr: 62°30'	Kr: 90°	Kr: 107°30'	Kr: 93°	Kr: 62°30'
A271	A272	A273	A308	A309	A310	A311
S***-SDQCR/L	A***-SDUCR/L	S***-SDZCR/L	E***-SDQCR/L			
Kr: 107°30'	Kr: 93°	Kr: 85°	Kr: 107°30'			
A336	A337	A338	A357			

E

Index

- Ideal machining conditions
- Normal machining conditions
- Unfavourable machining conditions

VBGT	L	I.C	S	d
11 03	11	6,35	3,18	2,8

Turning inserts

VB** positive insert				HC ¹ (CVD)								HC ¹ (PVD)			HT	HC ²	HW															
				P	●●●●●●●●●●									●●	●●																	
				M		●●									●●	●●																
				K																												
				N											●●				●●	●●												
				S											●●	●●			●●	●●												
				H																												
ISO				r	a _p	f	YBC103	YB6315	YBC152	YBC203	YBC252	YBC352	YBM153	YBM253	YBD102	YB7315	YBD152	YBD152C	YBG101	YBG102	YBG105	YBG205H	YB9320	YPD201	YBS103	YNG151	YNT251	YNG151C	YD101	YD201		
QF Finishing	VBGT110301-QF	0,1	0,05-0,2	0,03-0,1																		○										
	VBGT110302-QF	0,2	0,1-0,4	0,05-0,2																			○									
	VBGT110302-QF	0,2	0,1-0,4	0,05-0,2																									○			
	VBGT110304-QF	0,4	0,4-1	0,1-0,3																				○								

● Ex stock ○ On demand

HC¹ Coated carbide
 HT Uncoated cermet
 HC² Coated cermet
 HW Uncoated carbide

Tool holder			
SVJBR/L	SVABR/L	SVVBN	S***-SVXBR/L
Kr: 93°	Kr: 90°	Kr: 72°30'	Kr: 93°
A274	A275	A276	A347

A

Turning

B

Milling

C

Drilling

D

Technical Information

E

Index



SMP09 slot mill cutting system

Indexable milling

System code – milling bodies	B16–B17
ISO-Code – inserts	B18–B19
SMP09 slot mill cutting system	B20–B25
Recommended cutting data	B26–B29

B

A

Turning

B

Milling

C

Drilling

D

Technical
Information

E

Index

FM A 12 050 – A22 O – N 06 – 04 (L) (AC)

1 2 3 4 5 6 7 8 9 10 11

Type	
Code	Description
BM	Profile milling
CM	Chamfer milling
EM	Square shoulder milling
FM	Face milling
HM	Helical milling
SM	Slot milling
TM	T-slot milling
XM	Special

1

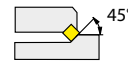
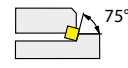
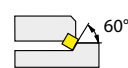
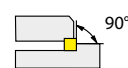
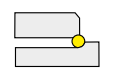
Entering angle	
A	
E	
D	
P	
R	

2

Serial number

3





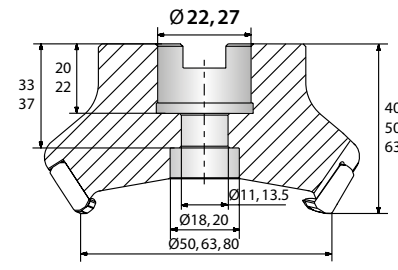
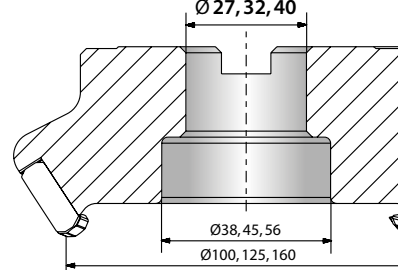
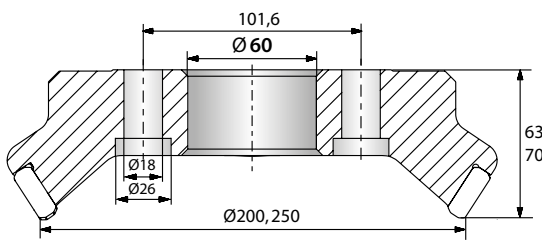
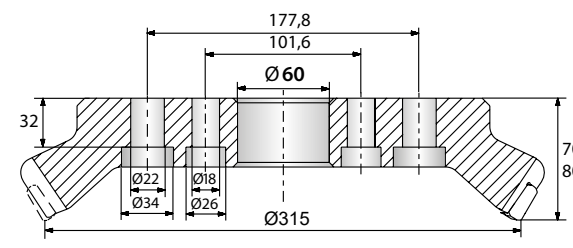





Nominal diameter [mm]	
Code	Description
025	25
050	50
160	160
315	315
...	

4







Type and size of tool holders			
Code	Type	Code	Type
A	<p>Nominal diameter $\varnothing 50 - 80$ mm</p> 	B	<p>Nominal diameter $\varnothing 100 - 160$ mm</p> 
C	<p>Nominal diameter $\varnothing 200 - 250$ mm</p> 	D	<p>Nominal diameter $\varnothing 315$ mm</p> 
G	Straight shank	XP	Weldon shank
K	Bore with keyway		

5









With respect to mounting please adhere to the information provided by the tool holder manufacturer.

Insert shape	
A 	C 
H 	L 
M 	O 
P 	R 
S 	T 
W 	X Special
Z Special	

6

Clearance angle	
B 	C 
D 	E 
F 	N 
P 	

7

Cutting edge length l [mm]	
Insert shape	
	
A	C, M
	
H, O, P	L
	
R	S
	
T	W

8

Number of teeth

9

Cutting direction	
Code	Description
L	Left

10

Cooling	
Code	Description
C	Inner cooling
AC	Air cooling

11



Tools with B coupling and inner coolant supply require the following spare parts:





Coolant clamp screw



Coolant shower plate



Spare parts (B coupling with inner coolant supply)

		B27	B32	B40	B40
	Ø	80	100	125	160
	Coolant clamp screw	LDB27C	LDB32C	LDB40C	LDB40C
	Coolant shower plate	B27-002-CP	B32-002-CP	B40-002-CP	B40-003-CP

When purchasing tools with inner coolant supply and B coupling these spare parts are included in delivery.

A

Turning

B

Milling

C

Drilling

D

Technical Information

E

Index

S P K N 12 04 ED T21K R – DM

1 2 3 4 5 6 7 8 9 10

A

Turning

B

Milling

C











Drilling







D





Technical Information

E

Index

Insert shape	
A 	C 
H 	L 
M 	O 
P 	R 
S 	T 
W 	X Special
Z Special	















Clearance angle	
B 	C 
D 	E 
F 	N 
P 	









Tolerance class			
			
Code	I.C [mm]	m [mm]	S [mm]
A	±0,025	±0,005	±0,025
C	±0,025	±0,013	±0,025
E	±0,025	±0,025	±0,025
F	±0,013	±0,005	±0,025
G	±0,025	±0,025	±0,130
H	±0,013	±0,013	±0,025
J	±0,05-0,13	±0,005	±0,025
K	±0,05-0,13	±0,013	±0,025
L	±0,05-0,13	±0,025	±0,025
M	±0,05-0,13	±0,08-0,18	±0,130
N	±0,05-0,13	±0,08-0,18	±0,025
U	±0,08-0,25	±0,13-0,38	±0,130

1

2

3

Fastening features (metric)	
Insert shape	
A 	B 
C 	F 
G 	H 
J 	M 
N 	Q 
R 	T 
U 	W 
X Special	

Cutting edge length l [mm]	
Insert shape	
	
A	C, M
	
H, O, P	L
	
R	S
	
T	W

4

5

Insert thickness S [mm]			
Code	S	Code	S
00	0,79	05	5,56
T0	0,99	T5	5,95
01	1,59	06	6,35
T1	1,98	T6	6,75
02	2,38	07	7,94
T2	2,58	09	9,52
03	3,18	T9	9,72
T3	3,97	11	11,11
04	4,76	12	12,70
T4	4,96		

6

Angle			
Code	Kr	Code	an
A	45°	A	3°
D	60°	B	5°
E	75°	C	7°
F	85°	D	15°
P	90°	E	20°
Z	Special	F	25°
		G	30°
		N	0°
		P	11°
		Z	Special

7

Chamfer							
Code	Type	Code	Angle	Code	Width [mm]	Code	Position
F		0	5°	0	0,10	K	
E		1	10°	1	0,15		
T		2	15°	2	0,20		
S		3	20°	3	0,25		
		4	25°	4	0,30		
		5	30°	5	0,35		
				6	0,40		
				7	0,45		
						W	
						-	

8

Cutting direction	
Code	Description
R	Right
L	Left
N	Right and left

9

Chip breakers

10

A

Turning

B

Milling

C

Drilling

D

Technical Information

E

Index

SMP09 slot mill cutting system

Highly versatile tangential milling system

YOUR BENEFITS

- **Highly versatile tool** for slot, face and square shoulder milling
- Groove widths of 10–20 mm and diameters of 80–315 mm possible for **maximum flexibility**
- Smooth cutting action and high stability for a **top-quality surface finish**
- Extremely well suited for machining **steel, stainless steel and cast iron**
- **Efficient machining operations** thanks to four-edged LNGX insert

Mounted tangentially
for stability and higher
productivity

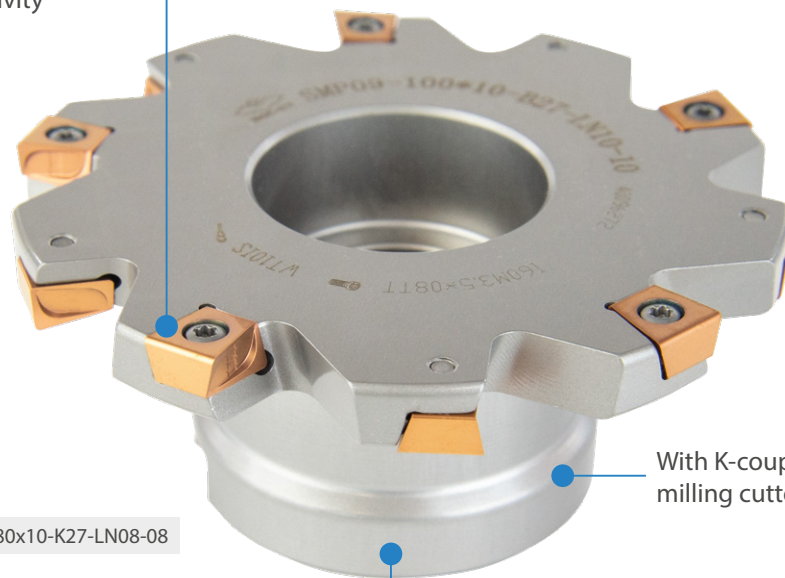

Fig.: SMP09-080x10-K27-LN08-08

With K-coupling and as a shell-type
milling cutter (versions A, B and C)

Diameter range 80–315 mm

Insert grades

YBM253

CVD
P20–P40
M15–M35

YB9320

PVD
P10–P30
M10–M25

Chip breaker

LNGX-GM



General machining

Large chip groove for
controlled chip removal

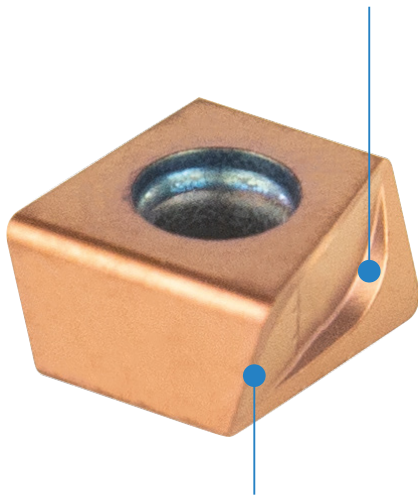

Low cutting forces thanks to
soft cutting design

Cutting radius 0.4–5.0 mm

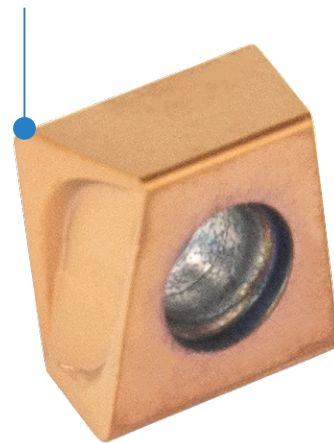
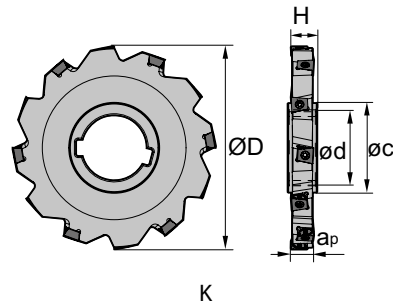
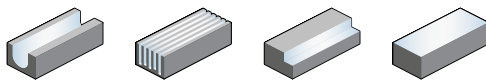

Fig.: LNGX0804-GM YB9320

Slot milling

SMP09 Kr: 90°



Article	*	Stock	Dimensions [mm]						Teeth	Coupling	kg	Insert
			ØD	ød	Øc	H	ap	ae max				
SMP09-080x10-K27-LN08-08	●	●	80	27	43	14	10	17	8	K	0,20	
SMP09-100x10-K32-LN08-10	●	●	100	32	47	14	10	25	10	K	0,37	
SMP09-125x10-K40-LN08-12	●	●	125	40	55	14	10	34	12	K	0,50	LNGX0804*
SMP09-160x10-K40-LN08-14	●	●	160	40	62	14	10	47	14	K	1,00	
SMP09-200x10-K50-LN08-16	●	●	200	50	72	14	10	62	16	K	1,60	
SMP09-100x12-K32-LN08-10	●	●	100	32	47	16	12	25	10	K	0,40	
SMP09-125x12-K40-LN08-12	●	●	125	40	55	16	12	34	12	K	0,60	LNGX0804*
SMP09-160x12-K40-LN08-14	●	●	160	40	62	16	12	47	14	K	1,10	
SMP09-200x12-K50-LN08-16	●	●	200	50	72	16	12	62	16	K	1,80	
SMP09-100x14-K32-LN10-10	○	○	100	32	47	18	14	25	10	K	0,40	
SMP09-125x14-K40-LN10-12	○	○	125	40	55	18	14	34	12	K	0,90	LNGX1005**
SMP09-160x14-K40-LN10-14	○	○	160	40	62	18	14	47	14	K	1,60	
SMP09-200x14-K50-LN10-16	○	○	200	50	72	18	14	62	16	K	2,50	
SMP09-125x16-K40-LN10-12	●	●	125	40	55	20	16	34	12	K	1,00	
SMP09-160x16-K40-LN10-14	●	●	160	40	62	20	16	47	14	K	1,80	LNGX1005**
SMP09-200x16-K50-LN10-16	●	●	200	50	72	20	16	62	16	K	2,90	
SMP09-125x18-K40-LN10-12	○	○	125	40	55	24	18	34	12	K	1,20	
SMP09-160x18-K40-LN10-14	○	○	160	40	62	24	18	47	14	K	2,10	LNGX1005**
SMP09-200x18-K50-LN10-16	○	○	200	50	72	24	18	62	16	K	3,40	
SMP09-250x18-K50-LN10-18	○	○	250	50	80	24	18	83	18	K	5,50	
SMP09-125x20-K40-LN14-10	●	●	125	40	55	26	20	34	10	K	1,20	
SMP09-160x20-K40-LN14-12	●	●	160	40	62	26	20	47	12	K	2,10	LNGX1407**
SMP09-200x20-K50-LN14-14	●	●	200	50	72	26	20	62	14	K	3,50	
SMP09-250x20-K50-LN14-16	●	●	250	50	80	26	20	83	16	K	5,80	
SMP09-160x25-K40-LN14-12	○	○	160	40	62	30	25	47	12	K	2,80	
SMP09-200x25-K50-LN14-14	○	○	200	50	72	30	25	62	14	K	4,50	LNGX1407**
SMP09-250x25-K50-LN14-16	○	○	250	50	80	30	25	83	16	K	7,50	

● Ex Stock ○ On demand

* With internal cooling

Slot milling

SMP09 Kr: 90°

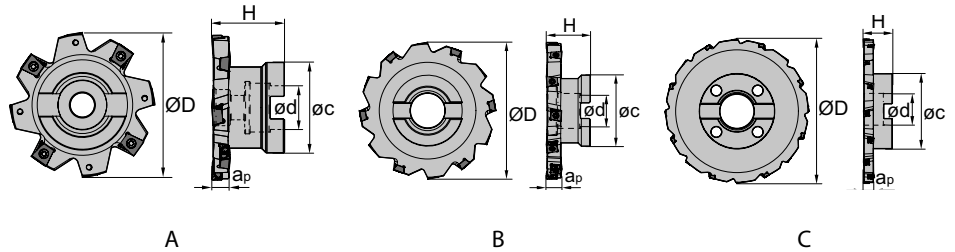
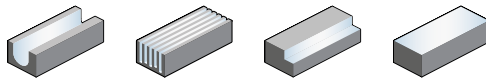

Article	* Stock	Dimensions [mm]							Teeth	Coupling	kg	Insert
		ØD	ød	Øc	H	ap	ae max					
SMP09-080x10-A22-LN08-08	●	80	22	45	40	10	20	8	A	0,40		
SMP09-100x10-B27-LN08-10	●	100	27	55	45	10	24	10	B	0,60		
SMP09-125x10-B32-LN08-12	●	125	32	65	45	10	33	12	B	1,00	LNGX0804*	
SMP09-160x10-B40-LN08-14	●	160	40	80	50	10	42	14	B	2,00		
SMP09-200x10-C40-LN08-16	●	200	40	92	50	10	53	16	C	2,90		
SMP09-100x12-B27-LN08-08	●	100	27	55	45	12	24	10	B	0,60		
SMP09-125x12-B32-LN08-12	●	125	32	65	45	12	33	12	B	1,00	LNGX0804*	
SMP09-160x12-B40-LN08-14	●	160	40	80	50	12	42	14	B	2,10		
SMP09-200x12-C40-LN08-16	●	200	40	92	50	12	53	16	C	2,90		
SMP09-100x14-B27-LN10-10	○	100	27	55	50	14	24	10	B	0,70		
SMP09-125x14-B32-LN10-12	○	125	32	65	50	14	33	12	B	1,20	LNGX1005**	
SMP09-160x14-B40-LN10-14	○	160	40	80	50	14	42	14	B	2,40		
SMP09-200x14-C40-LN10-16	○	200	40	92	50	14	53	16	C	3,60		
SMP09-125x16-B32-LN10-12	●	125	32	65	50	16	33	12	B	1,40		
SMP09-160x16-B40-LN10-14	●	160	40	80	50	16	42	14	B	2,60	LNGX1005**	
SMP09-200x16-C40-LN10-16	●	200	40	92	50	16	53	16	C	4,00		
SMP09-125x18-B32-LN10-12	●	125	32	65	50	18	33	12	B	1,50		
SMP09-160x18-B40-LN10-14	○	160	40	80	50	18	42	14	B	2,90	LNGX1005**	
SMP09-200x18-C40-LN10-16	○	200	40	92	50	18	53	16	C	4,30		
SMP09-250x18-C60-LN10-18	○	250	60	132	50	18	58	18	C	7,20		
SMP09-125x20-B32-LN14-10	●	125	32	65	50	20	33	10	B	1,60		
SMP09-160x20-B40-LN14-12	●	160	40	80	50	20	42	12	B	2,70	LNGX1407**	
SMP09-200x20-C40-LN14-14	●	200	40	92	50	20	53	14	C	4,60		
SMP09-250x20-C60-LN14-16	●	250	60	132	50	20	58	16	C	7,40		
SMP09-160x25-B40-LN14-12	●	160	40	80	50	25	42	12	B	3,20		
SMP09-200x25-C40-LN14-14	○	200	40	92	50	25	53	14	C	5,20	LNGX1407**	
SMP09-250x25-C60-LN14-16	○	250	60	132	50	25	58	16	C	8,60		
SMP09-315x25-C60-LN14-20	○	315	60	132	50	25	90	20	C	13,20		

● Ex Stock ○ On demand

* With internal cooling

A

Turning

B

Milling

C

Drilling

D

Technical Information



E

Index

Indexable milling Slot milling

A

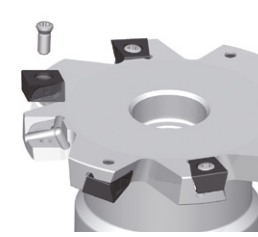

Turning

Spare parts								
Insert	LNGX0804**	LNGX0804**	LNGX1005**	LNGX1005**	LNGX1407**	LNGX1407**		
ØD	80-200	100-250	80-200	100-250	100-200	125-315		
	Screw (Insert)	I60M3*7	I60M3*7	I60M3,5*08TT (2,3N/m)	I60M3,5*08TT (2,3N/m)	I60M4*10 (3,4N/m)	I60M4*12 (3,4N/m)	
	Wrench (Insert)	WT09IP/IS	WT09IP/IS	WT10IS	WT10IS	WT15IS	WT15IS	

B

Milling











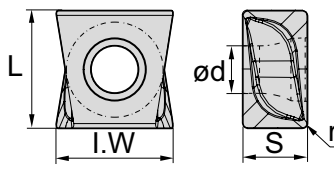





Milling insert

-  Ideal machining conditions
-  Normal machining conditions
-  Unfavourable machining conditions

LNGX	L	I.C	S	d
08 04	7,75	8,5	4	3,5
10 05	10,00	9,90	5,50	4,10
14 07	14,00	13,40	7,50	4,40

C

Drilling

LNGX milling insert			HC ¹ (CVD)						HC ¹ (PVD)				HT	HC ²	HW										
			P	M	K	N	S	H																	
																									
	ISO	r	YBC302	YBC301	YBC401	YBM253	YBM251	YBM351	YBD152	YBD252	YBG101	YBG102	YBG202	YBG212	YBS203	YBG205H	YB9320	YBG302	YBS303	YBG252	YNG151	YNG151C	YD101	YD201	
	LNGX080404-GM	0,4		○											●	○									
	LNGX080408-GM	0,8		○											●	○									
	LNGX080412-GM	1,2		○											●	○									
	LNGX080416-GM	1,6		○											●	○									
	LNGX080420-GM	2,0		○											●	○									
	LNGX080424-GM	2,4		○											●	○									
	LNGX100504-GM	0,4		○											●	○									
	LNGX100508-GM	0,8		○				○							●	○									
	LNGX100510-GM	1,0		○											●	○									
	LNGX100512-GM	1,2		○											●	○									
	LNGX100516-GM	1,6		○											●	○									
	LNGX100520-GM	2,0		○											●	○									
	LNGX100524-GM	2,4		○											○	○									
	LNGX100530-GM	3,0		○											○	○									
	LNGX100540-GM	4,0		○											○	○									

● Ex Stock ○ On demand

HC¹ Coated carbide
 HT Uncoated cermet
 HC² Coated cermet
 HW Uncoated carbide

E

Index

LNGX	L	I.C	S	d
08 04	7,75	8,5	4	3,5
10 05	10,00	9,90	5,50	4,10
14 07	14,00	13,40	7,50	4,40

- Ideal machining conditions
- Normal machining conditions
- Unfavourable machining conditions

Milling insert

LNGX milling insert		HC ¹ (CVD)						HC ¹ (PVD)					HT	HC ²	HW										
	P	●	●	●	●	●	●	●	●	●	●	●	●	●											
	M	●	●	●	●	●		●	●	●	●	●	●	●											
	K						●	●	●						●										
	N						●								●										
	S		●	●					●	●	●	●	●												
	H																								
ISO		r	YBC302	YBC301	YBC401	YBM253	YBM251	YBM351	YBD152	YBD252	YBG101	YBG102	YBG202	YBG212	YBS203	YBG205H	YB9320	YBG302	YBS303	YBG252	YNG151	YNG151C	YD101	YD201	
	LNGX140704-GM	0,4			○											●		○							
	LNGX140708-GM	0,8			○											●									
	LNGX140710-GM	1,0			○														○						
	LNGX140712-GM	1,2														○									
	LNGX140716-GM	1,6			○											○									
	LNGX140720-GM	2,0			○											○			○						
	LNGX140724-GM	2,4														○									
	LNGX140730-GM	3,0			○											○			○						
	LNGX140732-GM	3,2														○									
	LNGX140740-GM	4,0			○											○									
LNGX140750-GM	5,0			○											○										
LNGX140760-GM	6,0			○														○							

● Ex Stock ○ On demand

HC¹ Coated carbide
 HT Uncoated cermet
 HC² Coated cermet
 HW Uncoated carbide

A

Turning

B

Milling

C

Drilling

D

Technical Information

E

Index

Indexable milling – group 5 (SMP01/03/05/09)

	Material group	Composition / structure / heat treatment		Brinell hardness HB	Machining group	Starting values for cutting speed v_c [m/min]				
						HC (CVD)		HC (PVD)		
						YBC302	YBM253	YBG101	YB9320	
		a_e / D	a_e / D	a_e / D	a_e / D					
		1/4	1/4	1/4	1/4					
A Turning	P Unalloyed steel	approx. 0,15 % C	annealed	125	1	165	180	190	175	
		approx. 0,45 % C	annealed	190	2	145	155	165	150	
		approx. 0,45 % C	tempered	250	3	135	145	155	140	
		approx. 0,75 % C	annealed	270	4	120	130	135	125	
		approx. 0,75 % C	tempered	300	5	110	120	125	115	
B Milling	P Low-alloyed steel		annealed	180	6	145	155	165	150	
			tempered	275	7	120	130	135	125	
			tempered	300	8	110	120	125	115	
			tempered	350	9	95	100	105	100	
C Drilling	P High-alloyed steel and high-alloyed tool steel		annealed	200	10	85	90	95	90	
			hardened and tempered	325	11	60	65	70	65	
M Milling	M Stainless steel	ferritic/martensitic	annealed	200	12		90	95	90	
		martensitic	tempered	240	13		80	80	75	
		austenitic	quench hardened	180	14		100	105	95	
		austenitic-ferritic		230	15		80	80	75	
K Milling	K Grey cast iron	perlitic/ferritic		180	16			215	190	
		perlitic (martensitic)		260	17			125	115	
	K Cast iron with spheroidal graphite	ferritic		160	18			145	135	
		perlitic		250	19			95	90	
K Malleable cast iron	ferritic		130	20			175	160		
	perlitic		230	21			115	105		
N Milling	N Aluminium wrought alloys	cannot be hardened		60	22					
		hardenable	hardened	100	23					
	N Cast aluminium alloys	$\leq 12\% \text{ Si}$, cannot be hardened			75	24				
		$\leq 12\% \text{ Si}$, hardenable	hardened		90	25				
		$> 12\% \text{ Si}$, cannot be hardened			130	26				
	N Copper and copper alloys (bronze/brass)	machining steel, PB > 1%			110	27				
CuZn, CuSnZn			90	28						
S Milling	S Heat-resistant alloys	Fe-based alloys	annealed	200	30					
			hardened	280	31					
		Ni or Co base	annealed	250	32					
			hardened	350	33					
		cast	320	34						
S Titanium alloys	pure titanium		R_m 400	35						
	α and β alloys	hardened		R_m 1050	36					
H Milling	H Hardened steel		hardened and tempered	55 HRC	37					
			hardened and tempered	60 HRC	38					
	H Hard cast iron		cast	400	39					
	H Hardened cast iron		hardened and tempered	55 HRC	40					
X Milling	X Non-metallic materials	Thermoplasts			41					
		Thermosetting plastics			42					
		Plastic, glass-fibre reinforced GFRP			43					
		Plastic, carbon fibre reinforced CFRP			44					
		Graphite			45					
		Wood			46					

Note: The given cutting values are guide values, which were determined under ideal conditions.
 The values have to be adapted in individual cases.
 Feed rate recommendations on page B254.
 For examples of material for cutting tool groups view page D11.

Recommended feed rate

Indexable milling – group 5 (SMP01/03/05/09)

Material group	Feed rate per cutting edge [mm]								
	SMP01	SMP01	SMP01	SMP01	SMP01	SMP03	SMP03	SMP03	SMP05
	XSEQ1202	XSEQ1203	XSEQ12T3	XSEQ1204	XSEQ12T4	MPHT06	MPHT08	MPHT12	QC16
	Tool diameter [mm]								
	63-100	63-100	63-160	63-160	63-160	80-125	125-200	120-200	25-39
P Unalloyed steel	0,12	0,12	0,13	0,13	0,14	0,14	0,15	0,16	0,08
	0,11	0,11	0,12	0,12	0,13	0,13	0,14	0,15	0,08
	0,10	0,10	0,11	0,11	0,12	0,12	0,13	0,14	0,07
M Stainless steel	0,10	0,10	0,11	0,11	0,12	0,12	0,13	0,14	0,07
K Grey cast iron	0,11	0,11	0,12	0,12	0,13	0,13	0,14	0,15	0,08
	0,11	0,11	0,12	0,12	0,13	0,13	0,14	0,15	0,07
	0,11	0,11	0,12	0,12	0,13	0,13	0,14	0,15	0,07
N Aluminium wrought alloys									
S Heat-resistant alloys									
H Hardened steel									
X Non-metallic materials									

Note: The given cutting values are guide values, which were determined under ideal conditions.
The values have to be adapted in individual cases.

A

Turning

B

Milling

C

Drilling

D

Technical Information

E

Index

Feed rate per cutting edge [mm]					
SMP05	SMP09	SMP09	SMP09	SMP09	
QC22	LNGX0804	LNGX1005	LNGX1407		
Tool diameter [mm]					
44	-	-	-		
0,08	0,14	0,15	0,16		
0,08	0,13	0,14	0,15		
0,07	0,12	0,13	0,13		
0,07	0,12	0,13	0,14		
0,08	0,13	0,14	0,15		
0,07	0,13	0,14	0,15		
0,07	0,10	0,11	0,12		

A
Turning
B
Milling
C
Drilling
D
Technical Information
E
Index

zCLAMP Hydro
HSK-A63 250 L80
90505046300320080
MADE IN GERMANY
S/N 17242324

zClamp Hydro

Milling

Drilling

Threading

Reaming

zClamp Hydro

Secure tool clamping for maximum process reliability 32–33

Hydraulic expansion chucks

SK	34
JIS-BT	35
HSK-A	36

Accessories

Adapter sleeves	38–41
-----------------	-------

Secure tool clamping for maximum process reliability

YOUR BENEFITS

- **Lower tooling costs** since tools last up to 300 per cent longer*
- **Secure tool clamping** thanks to clamping forces of up to of 2,000 Nm
- **Top surface qualities** and **less noise** are possible thanks to vibration damping
- Tool changes are completed in seconds without the need for any peripheral equipment for **shorter changeover times**
- Consistent run-out accuracy of less than 0.003 mm for **maximum performance**

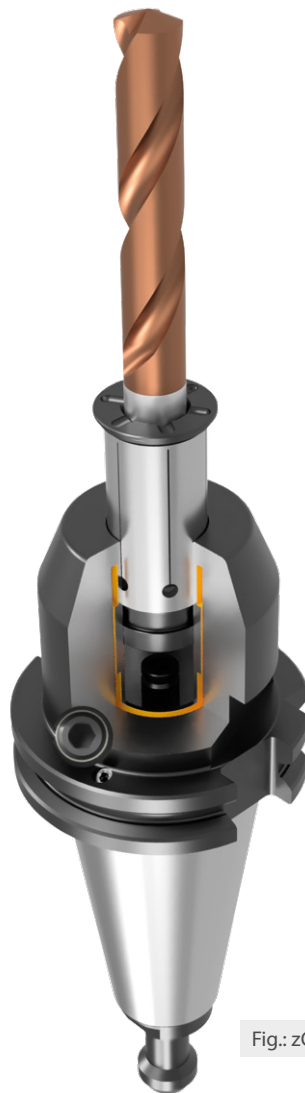

Fig.: zClamp Hydro SK40 Ø20 L64.5

* Verified in a study conducted by the wbk Institute for Production Science at the Karlsruhe Institute of Tech

Oil and lubricant residue is pushed into the **groove**, keeping the clamping surface dry while maintaining the clamping force.

The **expansion sleeve with chamber system** loops evenly around and clamps the entire surface of the tool shank. At the same time, the chamber system delivers optimum vibration damping.

Length adjustment screw makes it easy to pre-adjust the tool in next to no time.

The **actuation screw** can be tightened to the end stop without a torque wrench.

The base unit is available with the following interfaces: HSK/SK and JIS-BT.

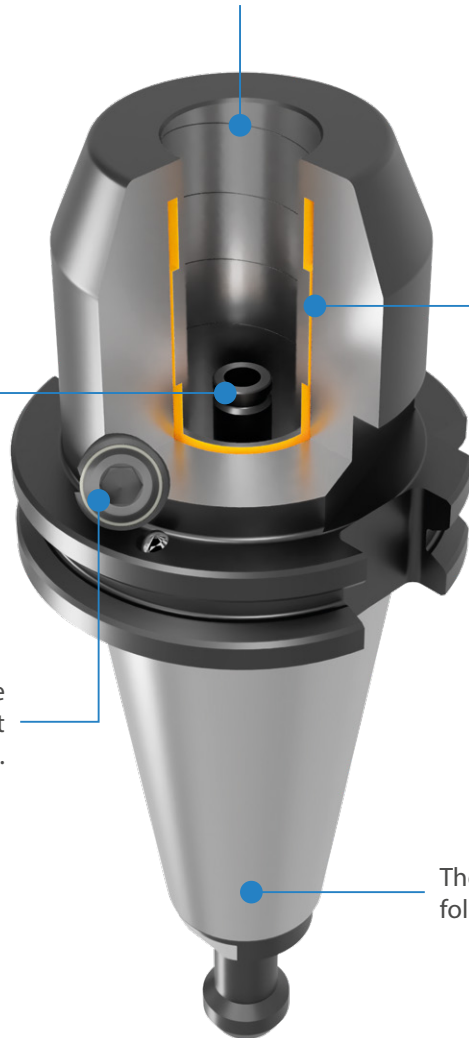

zClamp Hydro SK hydraulic expansion chucks

ISO 7388-1 AD/AF

- G2.5 balancing quality grade at 25,000 rpm
- Run-out accuracy of less than 0.003 mm at a projecting length of 2.5xD
- Available with axial length adjustment

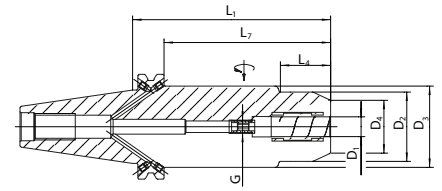
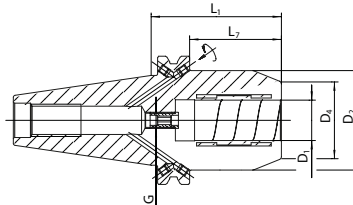

Article	Dimensions [mm]												Stock
	SK	D ₁	D ₂	D ₃	D ₄	L ₁	L ₂	L ₃	L ₄	L ₅	G	M _{min}	
9050514000812050	SK40	12	42	-	32	50	46	10	30.9	-	M8x1	110	○
9050514000816064	SK40	16	49.25	-	38	64.5	51	10	45.4	-	M8x1	350	○
9050514000820064	SK40	20	49.25	-	38	64.5	51	10	45.4	-	M8x1	520	○
9050514000832115	SK40	32	62.5	-	58.5	115	61	10	95.95	-	M8x1	800	○
9050514000812130	SK40	12	42	44.5	32	130	46	10	32	-	M8x1	110	○
9050514000816130	SK40	16	42	44.5	38	130	51	10	50	-	M8x1	400	○
9050514000820130	SK40	20	42	44.5	38	130	51	10	50	-	M8x1	400	○

● ex stock ○ on demand

M_{min} = guaranteed clamping force in Nm

zClamp Hydro JIS-BT hydraulic expansion chucks

ISO 7388 JD/JF

- G2.5 balancing quality grade at 25,000 rpm
- Run-out accuracy of less than 0.003 mm at a projecting length of 2.5xD
- Available with axial length adjustment

Tool holders

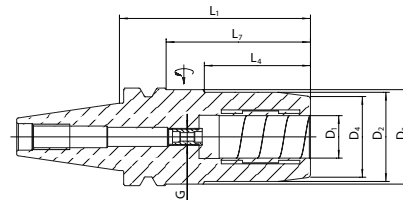
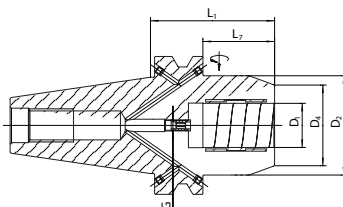

Article	Dimensions [mm]												Stock
	JIS-BT	D ₁	D ₂	D ₃	D ₄	L ₁	L ₂	L ₃	L ₄	L ₅	G	M _{min}	
90505034000812058	BT40	12	42	-	32	58	46	10	31	-	M8x1	110	○
90505034000816072	BT40	16	49.25	-	38	72.5	51	10	45.5	-	M8x1	350	○
90505034000820072	BT40	20	49.25	-	38	72.5	51	10	45.5	-	M8x1	520	○
90505034000832120	BT40	32	62.5	-	58.5	120	61	10	-	93	M8x1	800	○

● ex stock ○ on demand

M_{min} = guaranteed clamping force in Nm

zClamp Hydro HSK-A hydraulic expansion chucks

ISO 12164-1

- G2.5 balancing quality grade at 25,000 rpm
- Run-out accuracy of less than 0.003 mm at a projecting length of 2.5xD
- Available with axial length adjustment

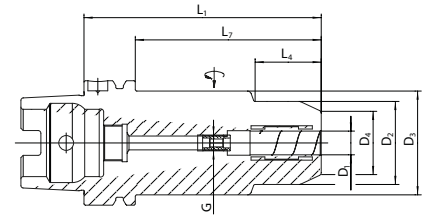
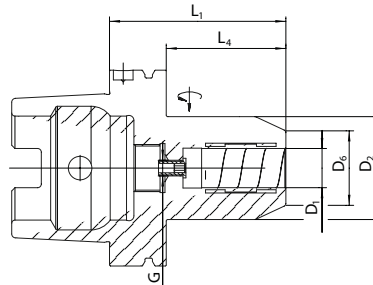

Article	Dimensions [mm]												Stock
	HSK-A	D ₁	D ₂	D ₃	D ₄	L ₁	L ₂	L ₃	L ₄	L ₅	G	M _{min}	
90505046300812080	HSK-A63	12	42	52.5	32	80	46	10	34	54	M8x1	110	○
90505046300816080	HSK-A63	16	52,5	-	38	80	51	10	54	-	M8x1	350	○
90505046300820080	HSK-A63	20	52,5	-	38	80	51	10	54	-	M8x1	520	○
90505046300832120	HSK-A63	32	62,5	-	58,5	120	61	10	94	-	M8x1	800	○
90505046300812130	HSK-A63	12	42	44.5	32	130	46	10	32	104	M8x1	110	○
90505046300816130	HSK-A63	16	42	44.5	38	130	51	10	50	104	M8x1	350	○
90505046300820130	HSK-A63	20	42	44.5	38	130	51	10	50	104	M8x1	400	○

● ex stock ○ on demand

M_{min} = guaranteed clamping force in Nm.

Accessories			
		Article	Stock
	HSK 63 coolant pipe	9799133	○



zClamp Hydro

Reaming

Milling

Drilling

Threading

Adapter sleeves

Wide clamping range thanks to adapter sleeves

YOUR BENEFITS

- **Maximum flexibility for optimum cost control:** one tool holder for several clamping diameters
- **Flexible length pre-adjustment** thanks to movable end stop
- **Higher clamping force** compared to direct clamping for greater process reliability
- **Precise results every time** thanks to run-out accuracy of less than 0.003 mm



Fig.: 90507292012

Fig.: zClamp Hydro SK40 Ø20 L64.5

YOUR BENEFITS

Peripheral cooling

- **Longer tool life** thanks to optimised coolant outlet located directly on the tool shank
- **Enhanced chip extraction** thanks to targeted application of coolant
- **Targeted cooling** made possible by coolant slot with nozzle geometry



Tool length L can be flexibly adjusted with all adapter sleeves using an adjustable end stop.

Adapter sleeve for hydraulic expansion tool holder (coolant-proof)

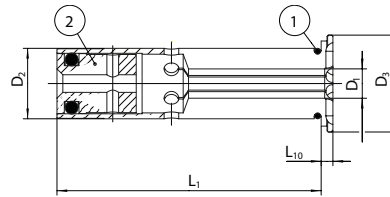
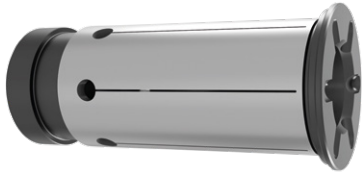

① O-ring seal ② Adjustable end stop

Article	Dimensions [mm]					Stock
	D ₁	D ₂	D ₃	L ₁	L ₁₀	
90507291203	3	12	16.5	45	2	○
90507291204	4	12	16.5	45	2	○
90507291205	5	12	16.5	45	2	○
90507291206	6	12	16.5	45	2	○
90507291208	8	12	16.5	45	2	○
90507291210	10	12	16.5	45	2	○
90507292003	3	20	24	50.5	2	○
90507292004	4	20	24	50.5	2	○
90507292005	5	20	24	50.5	2	○
90507292006	6	20	24	50.5	2	○
90507292007	7	20	24	50.5	2	○
90507292008	8	20	24	50.5	2	○
90507292009	9	20	24	50.5	2	○
90507292010	10	20	24	50.5	2	○
90507292011	11	20	24	50.5	2	○
90507292012	12	20	24	50.5	2	○
90507292013	13	20	24	50.5	2	○
90507292014	14	20	24	50.5	2	○
90507292015	15	20	24	50.5	2	○
90507292016	16	20	24	50.5	2	○
90507293206	6	32	35.5	60.5	2	○
90507293208	8	32	35.5	60.5	2	○
90507293210	10	32	35.5	60.5	2	○
90507293212	12	32	35.5	60.5	2	○
90507293214	14	32	35.5	60.5	2	○
90507293216	16	32	35.5	60.5	2	○
90507293218	18	32	35.5	60.5	2	○
90507293220	20	32	35.5	60.5	2	○
90507293225	25	32	35.5	60.5	2	○

● ex stock ○ on demand

Note: For shank tolerances of h6 or higher.

Accessories		Article	Stock
	Sleeve removal tool	9937987	●

Adapter sleeve for hydraulic expansion tool holder (peripheral cooling)

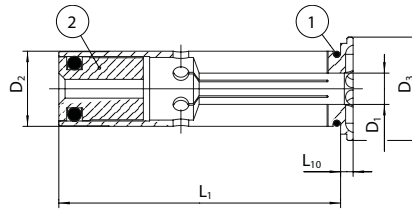
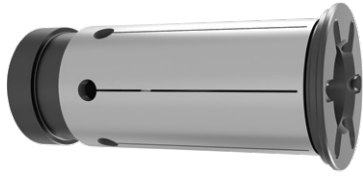

① O-ring seal ② Adjustable end stop

Article	Dimensions [mm]					Stock
	D ₁	D ₂	D ₃	L ₁	L ₁₀	
90507301203	3	12	16.5	45	2	○
90507301204	4	12	16.5	45	2	○
90507301205	5	12	16.5	45	2	○
90507301206	6	12	16.5	45	2	○
90507301208	8	12	16.5	45	2	○
90507302003	3	20	24	50.5	2	○
90507302004	4	20	24	50.5	2	○
90507302005	5	20	24	50.5	2	○
90507302006	6	20	24	50.5	2	○
90507302007	7	20	24	50.5	2	○
90507302008	8	20	24	50.5	2	○
90507302009	9	20	24	50.5	2	○
90507302010	10	20	24	50.5	2	○
90507302011	11	20	24	50.5	2	○
90507302012	12	20	24	50.5	2	○
90507302013	13	20	24	50.5	2	○
90507302014	14	20	24	50.5	2	○
90507302015	15	20	24	50.5	2	○
90507302016	16	20	24	50.5	2	○
90507303206	6	32	35.5	60.5	2	○
90507303208	8	32	35.5	60.5	2	○
90507303210	10	32	35.5	60.5	2	○
90507303212	12	32	35.5	60.5	2	○
90507303214	14	32	35.5	60.5	2	○
90507303216	16	32	35.5	60.5	2	○
90507303218	18	32	35.5	60.5	2	○
90507303220	20	32	35.5	60.5	2	○
90507303225	25	32	35.5	60.5	2	○

● ex stock ○ on demand

Note: For shank tolerances of h6 or higher.

Accessories		Article	Stock
	Sleeve removal tool	9937987	○

zCLAMP Hydro
HSK-A63 Ø20 L80
90505046300820080
MADE IN GERMANY
S/N 17242324

zClamp Hydro

Threading

Milling

Drilling

Reaming

The easy way to order your custom-made special tool

Are there specific applications at your company where having custom tools tailored to your unique needs would deliver real benefits both in terms of logistics and at a technical and commercial level? ZCC Cutting Tools is there to advise and assist you during the planning, development and ordering process. Use our new online tool to request a special tool and get your personal quotation in just a few short steps.

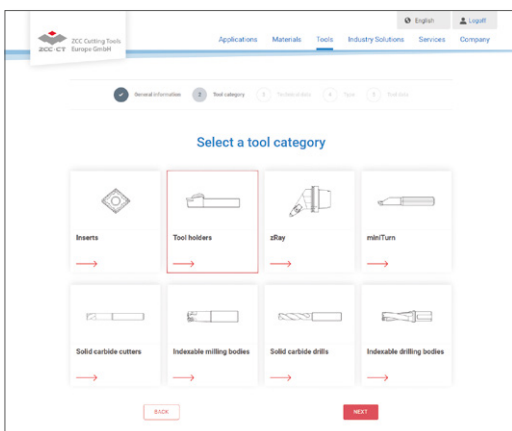

'Online tool for special tools' launch page where you can select the tool category

Selecting the tool category

Scan the QR code on this page to go directly to the launch page of our online tool where you can request the special tool you need. You can begin by selecting the tool category you need. It's that easy.

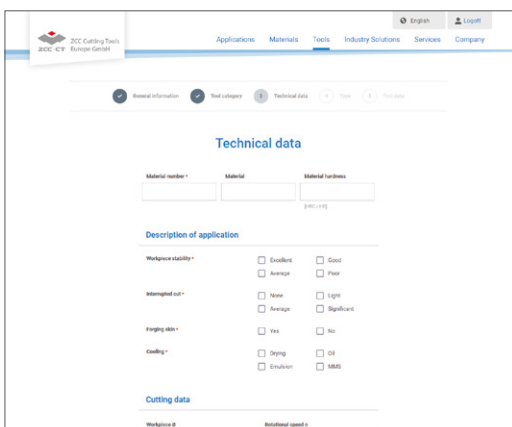

Define the relevant tool parameters

Defining the tool parameters

You are now guided step by step through the process. You can also securely upload your drawings, diagrams and 3D models (where available).

The fast and direct way to order your special tool from ZCC Cutting Tools Europe.



Now go directly to the new **special tool form** on our website and get started.

www.zccct-europe.com/en/tools/special-tools



Go to PDF online

European Headquarters
ZCC Cutting Tools Europe GmbH
www.zccct-europe.com
Wanheimer Str. 57, 40472 Düsseldorf, Germany
Tel.: +49 (0)211-989240-0
Fax: +49 (0)211-989240-111
E-mail: info@zccct-europe.com

Branch Office France
ZCC Cutting Tools Europe GmbH
Succursale Française
www.zccct-europe.com
14, Allée Charles Pathé, 18000 Bourges, France
Tel.: +33 (0)2 45 41 01 40
Fax: +33 (0)800 74 27 27
E-mail: ventes@zccct-europe.com

Branch Office UK
ZCC Cutting Tools Europe GmbH
UK Division
www.zccct-europe.com
4200 Waterside Centre, Solihull Parkway,
Birmingham Business Park,
Birmingham, West Midlands, B37 7YN, UK
Tel.: +44 (0)121-809 5469
Fax: +49 (0)211-989240-111
E-mail: infouk@zccct-europe.com



© Copyright by ZCC Cutting Tools Europe GmbH